

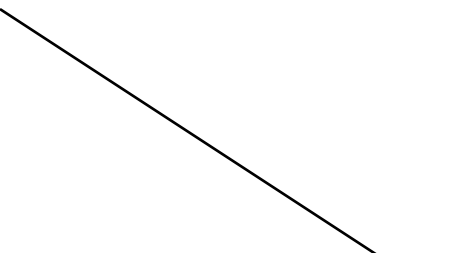

I



$$= \sqrt{\frac{\Delta}{\rho}} \times \varepsilon \times \frac{\pi}{2} \times \beta \times \frac{\sqrt{\Delta}}{\sqrt{\rho} \cdot \sqrt{-\beta}}$$

$$= \sqrt{\frac{\Delta}{\rho}} \times \varepsilon \times \frac{\pi}{2} \times \beta \times \frac{\sqrt{\Delta} \cdot \rho}{\sqrt{-\beta}}$$

m! ^ Ö

γ
P

ü: P, C, G, U, Y, Q, E, P`



$$= \frac{\varepsilon \cdot \cdot \sqrt{\rho}}{\varepsilon \cdot \cdot \sqrt{\rho}} \times$$

$$= \times \frac{\varepsilon \times \times \sqrt{\rho}}{\varepsilon \times \times \sqrt{\rho}} = \times \frac{\varepsilon \times \times \sqrt{\times \times}}{\varepsilon \times \times \sqrt{\times \times}}$$



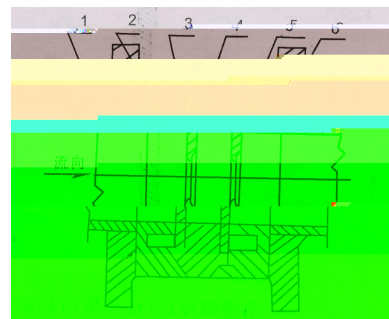
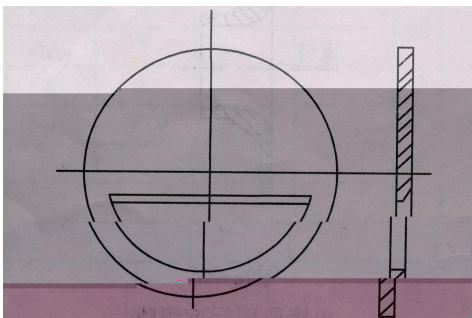
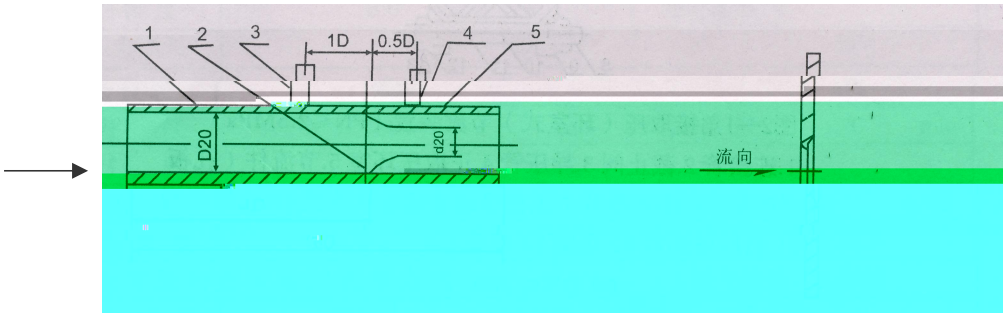
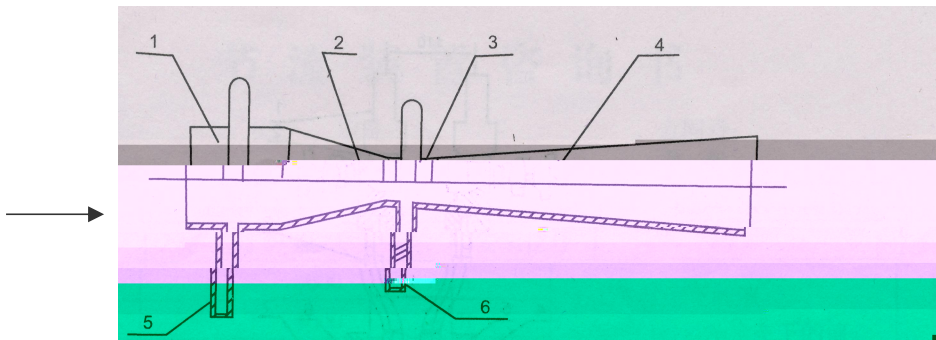

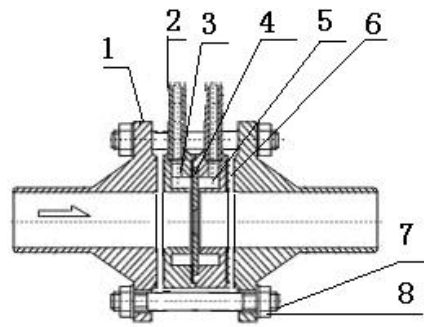



Maxonic 万讯

股票代码：300112

深圳万讯自控股份有限公司

地址：深圳市南山区高新技术产业园北区3号路万讯大厦

电话：0755-86250388 传真：0755-86250389

<http://www.maxonic.com.cn> E-mail: info@maxonic.com.cn

腾讯微博: <http://t.qq.com/maxonic>

新浪微博: <http://weibo.com/maxonic>



万讯官方微信

售后服务 | 4000 300 112

版本号：202001